

“No-regrets path to Open Standards Adoption in AMI Systems”

EPRI AMI/HAN Webcast
June 16, 2009

Rich Creegan – VP Marketing & Strategy

Ed May – Director Product Marketing

Michael Stuber – Manager System Architecture



Itron At A Glance

- **Major provider of Smart Electric, Gas and Water Meters**
- **Data Collection Systems**
 - > Smart Grid Solutions
 - > Advanced Metering Infrastructure (AMI) Solutions
 - > Automated Meter Reading (AMR) Systems
- **Utility and Energy Management Software Solutions**
 - > Meter Data Management & Demand Response
 - > Web-enabled Customer Care Energy, Cost, and Rate Analysis
 - > Revenue Assurance
 - > Load Forecasting and Load Research
- **2008 Financial Projections**
 - > 2008 Revenues > \$1.8 Billion
 - > EBITDA > \$287 Million
- **Worldwide Employees > 8,500 with over 2,600 in North America**
- **Worldwide Customers > 8,000 in 130 countries**
- **Operations and Manufacturing in over 30 Countries**

Commitment to Open, Interoperable Standards

Organizations / Initiatives / Focus Groups

- **UCA** International Users Group-OpenSG, UtilityAMI, OpenHAN, **AMI-Security**, AMI-Enterprise (Participation)
- **EPRI** Intelligrid (Tracking)
- **GridWise** Alliance (Member)
- Gridwise Architecture Council (Tracking)
- **DOE** Smart Grid Task Force (Participating)
- **NEMA** Smart Grid Advisory Panel (Participating)
- IEC SG3 Advisory Panel (Tracking)
- **ANSI** standards (Participating) related focus: C12.19, C12.22
- **IEEE** Smart Grid Task Force (tracking) related focus: SUN initiative
- **NARUC-FERC** Smart Grid Collaborative (Participating)
- **ZigBee** Alliance (Board member, Technical Editor, Co-Chair)
- **NIST** Smart Grid Interoperability Roadmap (Workshop participation)

Collaborative Open Letter to NIST

- Support and participation of the NIST process
- Smart Grid will clearly be a system-of-systems communicating over a network-of-networks, just like the Internet
- Focus on interoperability with priority towards Intersystem standards recognizing the benefits of existing solutions currently being deployed
- Standards should be agnostic to the physical layer, recognizing a real need for flexibility to provide full deployment over the territory over time
- Internet Protocol is one of many alternatives to be considered for automation and process control systems.
 - > MODBUS / BACNET / DNP3 / HomePlug
- Adaptors, translators, and/or proxy servers should be considered for achieving Inter-System interoperability
- Selected standards should be openly published and ratified by SDO, Industry Alliance, or well recognized users group
- Referenced Smart Grid Standards Adoption: Utility Industry Perspective

Open Standards

- Interoperability and transportability are key
 - > Open interfaces between layers, segments and domains
 - > Promote innovative ecosystem of applications not yet envisioned
 - > Ensure simplified “technology refresh”, upgrades and expansion
- Connectivity AND Communications

The Internet Protocol Suite (“IP”)		
Layer	Function	Examples
4. Application	Network process to application	HTTP, DNP3.0, C12.22
3. Transport	End-to-end connections and reliability	TCP, UDP
2. Internet	Path determination and logical addressing	IP
1. Link or Subnet	Methods that link between adjacent network nodes	Ethernet (MAC & LLC), RF LAN

EPRI's IntelliGrid Guidelines

- Follow all the key guidelines for AMI as per IntelliGrid (EPRI) Attributes of Compliance
- The building blocks (hardware, firmware, software, middleware) of an Intelligrid compliant system have the following attributes:
 - > Support object modeling
 - > Employ self description
 - > Support the concepts of common services and generic interfaces
 - > Based on open, published standards
 - > Well defined interfaces and points of interoperability
 - > Facilitate device and network management
 - > Permit the implementation of adequate security policy
 - > Implements time synchronization

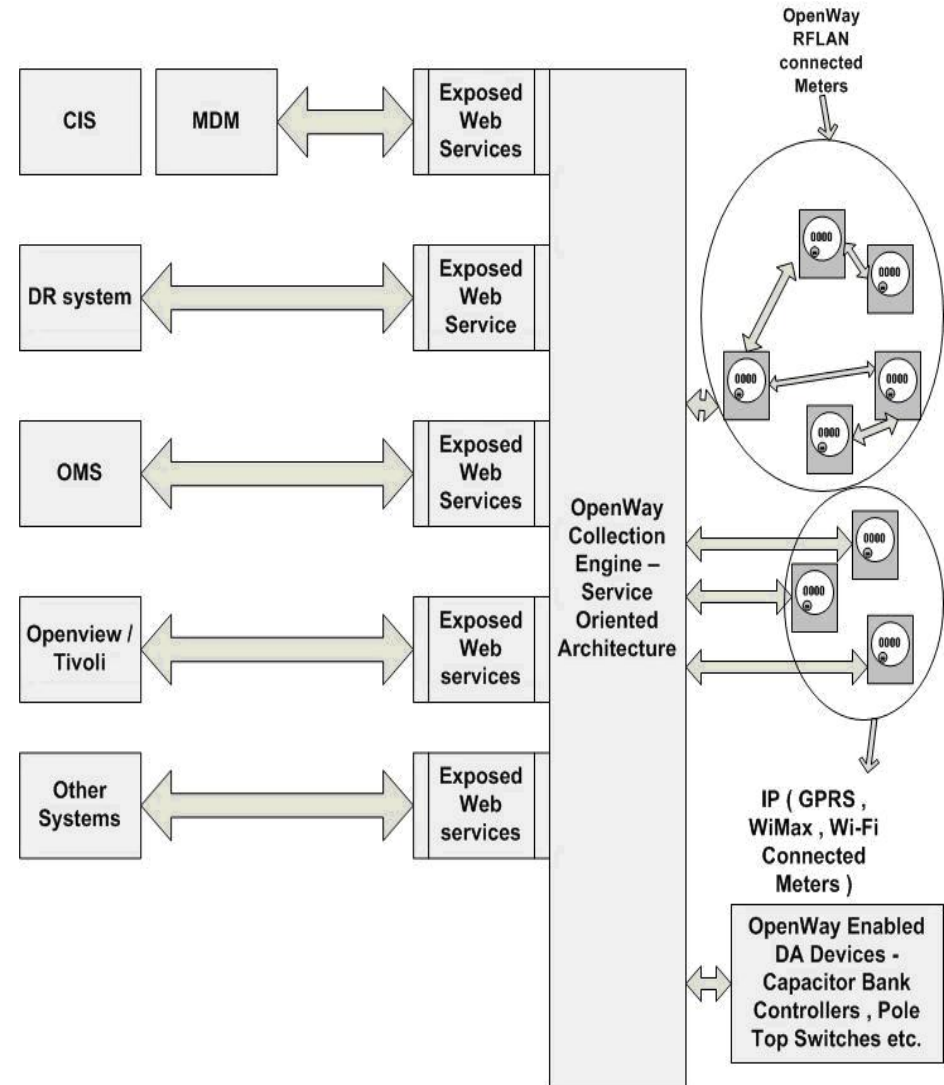

Smart Grid Standards Adoption: Utility Industry Perspective

“The grid will become “**smarter**” and more capable **over time** and the supporting **standards** must also **evolve** to support higher degrees of interoperability enabling more advanced capabilities over time. The implication of the SG evolution for standards adoption is that at any point in time the industry will be characterized by a mix of old technology, last generation technology, current generation smart technology and “Greenfield” technology opportunities.”

Source: [Smart Grid Standards Adoption: Utility Industry Perspective](#), OpenSG Subcommittee of the Utility Communication Architecture International User Group, and Smart Grid executive Working Group.

FERC Reference to Inter vs. Intra System Communications

System of Systems

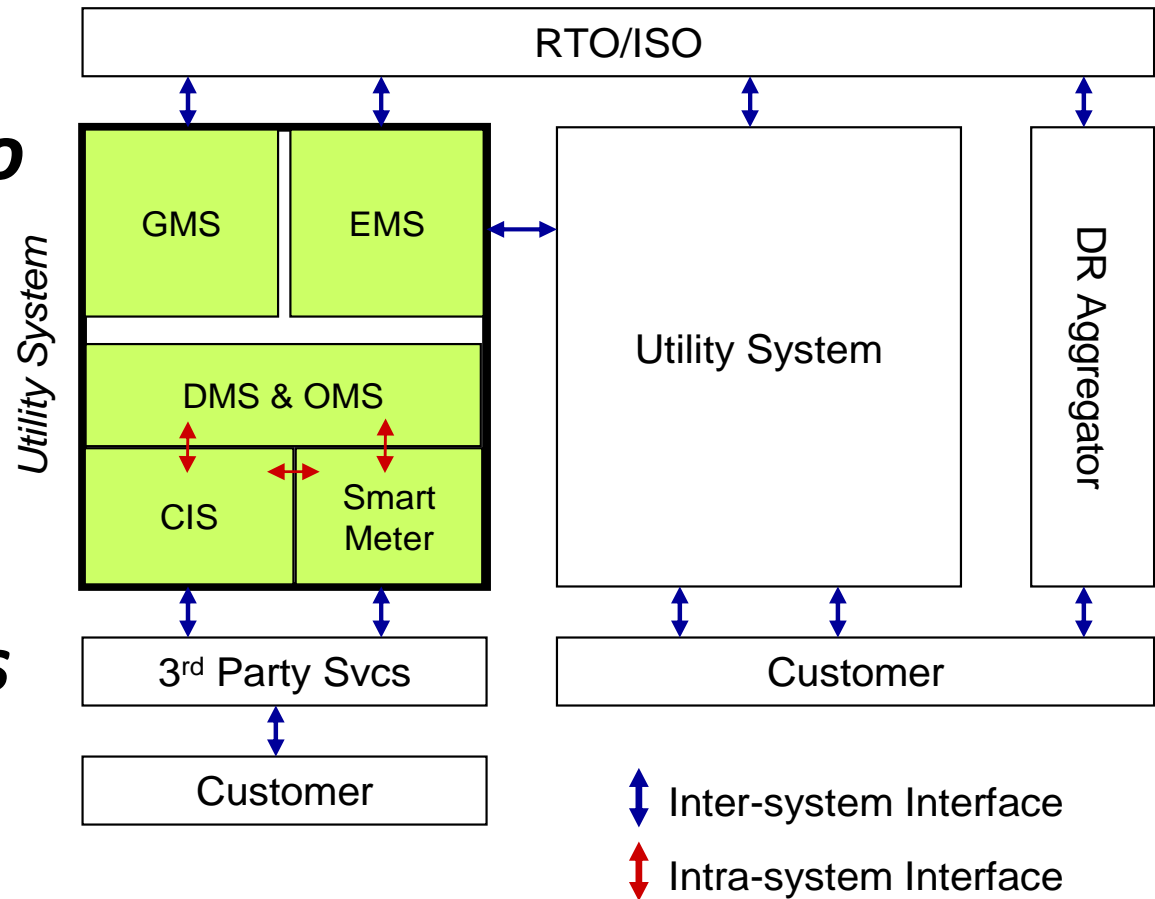

Source: [Smart Grid Standards Adoption: Utility Industry Perspective](#), OpenSG Subcommittee of the Utility Communication Architecture International User Group, and Smart Grid executive Working Group.

Inter vs Intra-system communications

- **“inter-system”** interfaces are those interfaces between the boundary of the utility’s transmission, distribution and customer systems and the boundary of another entity’s systems or devices (i.e., the interface between a utility meter and customer device, or between utility grid management system and RTO system)
- **“intra-system”** interfaces are those interfaces within the boundary of the utility’s system of transmission, distribution and customer systems (e.g., interface between utility meter and utility communication network or utility fault detector and distribution management system).

Source: [Smart Grid Standards Adoption: Utility Industry Perspective](#), OpenSG Subcommittee of the Utility Communication Architecture International User Group, and Smart Grid executive Working Group.

Inter

Intra-system communications

Inter

ZigBee®	Itron RFLAN or GPRS or CDMA or PLC or other	WEB SERVICES
IEEE 802.15.4	Itron RFLAN or TCP/IP or UDP/IP or PLC or other	SOA, Published WDSLs
ZigBee® Smart Energy Profile	ANSI C12.22 / C12.19 STANDARDS	WEB SERVICES

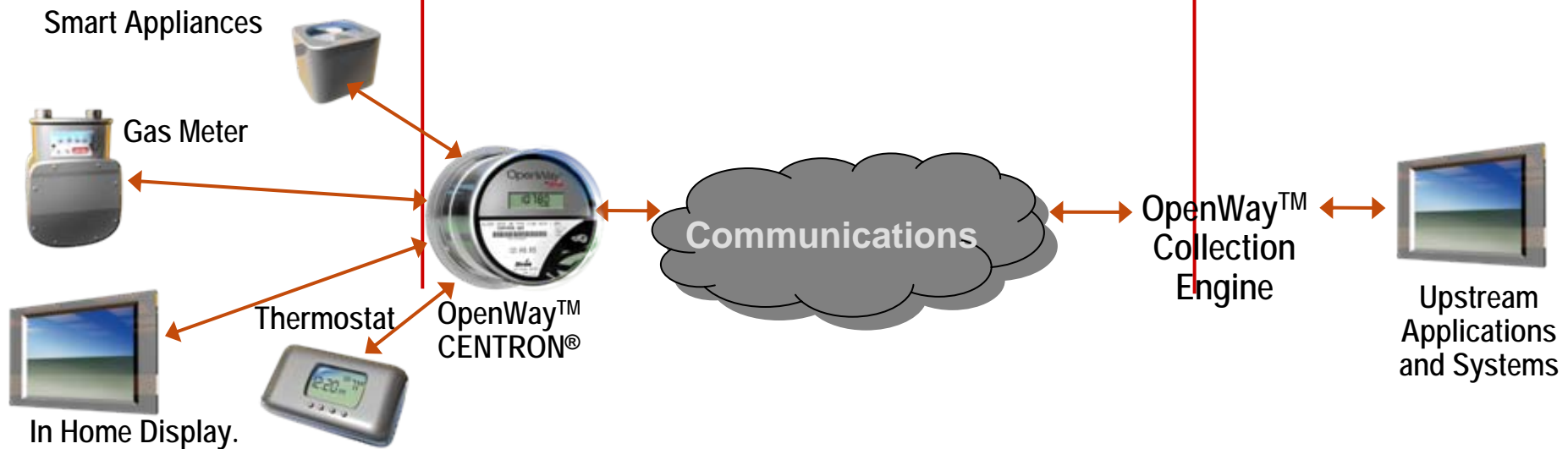

ZigBee Smart Energy profile

- ▶ ZigBee Smart Energy is the open-standard application for energy management.
 - Designed in conjunction with utilities and manufacturers
 - Tested and certified interoperability
- ▶ Smart Energy supports several features targeted towards Home Automation and Demand Response
- ▶ Certified devices for secure home-area networks are available today
 - Meters, thermostats, load control, outlets, in-home displays

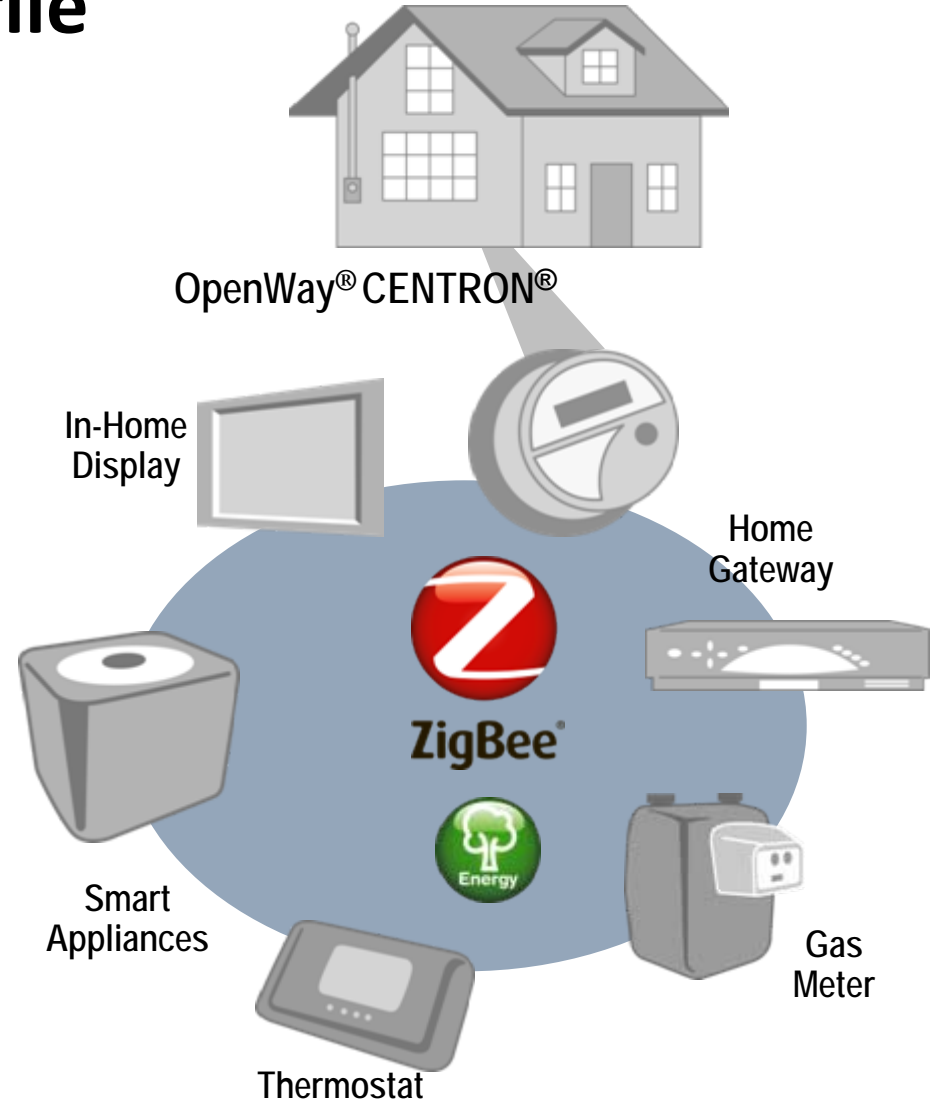

ANSI C12.22 Standard

- C12.22 is an application protocol that provides for the transport of C12.19 data tables over any network medium.
 - > A methodology for both session and “session-less” communications
 - > A common data encryption and security model
 - > A common addressing mechanism for use over both proprietary and non-proprietary network mediums
 - > Interoperability among metering devices within a common communication environment
 - > System integration with 3rd-party devices through common interfaces and gateway abstraction (non-C12.22 compliant)
 - > Both two-way and one-way communications with end devices
- Ratified and openly published specification through a SDO
- Referenced in Texas PUC Rulemaking for AMS and Louisiana legislation
- > 20m Smart Meters are under contract in NA utilizing C12.22
- Supports all currently defined use cases for AMI

Security

- Provide a completely security architecture to meet NERC cyber security standards and deploying FIPS compliant security modules
 - > Security not only at the communication network – but inherent in the application and all the way to the device
- A smart meter with an extensive metrology and communication feature set with the built-in horsepower required to run the security cryptographic modules necessary to meet the latest NERC standards

OpenWay Security Philosophy

- Committed to using industry, national, or international standards
 - > These include offerings from NERC, IEC, IETF, ISO, and NIST.
- Principal contributor to UtilityAMI and AMI-SEC
- Primary author of the AMI-SEC “AMI Risk Assessment & System Requirements” document.



OpenWay Security Philosophy

- Confidentiality
- Integrity
- Availability
- Authorization
- Identification & Authentication
- Access Control & Intrusion detection
- Non-repudiation



Summary

- George Arnold, “Operational not prescriptive”
- DOE/DOC leadership summit, “Tell us what you want us to do, don’t tell us how to do it.”
- Smart Grid will clearly be a system-of-systems communicating over a network-of-networks, just like the Internet
- Internet Protocol is one of many alternatives to be considered for automation and process control systems.
- Focus on interoperability with priority towards Intersystem standards recognizing the benefits of existing solutions currently being deployed.
- Recognition that true interoperability is achieved only when application layer standards for interface and data exchange are adopted.

 **Thank You.**

Rich Creegan
Ed May
Michael Stuber

Appendix