



Smarter Transmission

Paul Myrda

Technical Executive

Smarter Transmission Coordinator

May 10, 2011

Agenda

- Introductions
- Legal Notice
- Smarter Transmission Update
- NASPInet Demo featuring the Smart Grid Substations Lab
- Grid Transformation
- Upcoming Meetings of Interest

Legal Notices

- **Please observe these Antitrust Compliance Guidelines:**

- Do not discuss pricing, production capacity, or cost information which is not publicly available; confidential market strategies or business plans; or other competitively sensitive information
- Be accurate, objective, and factual in any discussion of goods and services offered in the market by others.
- Do not agree with others to discriminate against or refuse to deal with a supplier; or to do business only on certain terms and conditions; or to divide markets, or allocate customers
- Do not try to influence or advise others on their business decisions and do not discuss yours except to the extent that they are already public



Smarter Transmission

Agenda

- Introductions
- Legal Notice
- Smarter Transmission Update
- NASPInet Demo featuring the Smart Grid Substations Lab
- Grid Transformation
- Upcoming Meetings of Interest

White Paper – A Smarter Transmission Grid

Contents

- Introduction
- Need for a Smarter Tx Grid
- Global Smart Grid Initiatives
- Vision of a Smarter Tx Grid
- Technology Pillars
- Key Technologies and Initiatives
- Next Steps / Key Success Factors
- Achieving the Smarter Transmission Grid
- Leadership
- References

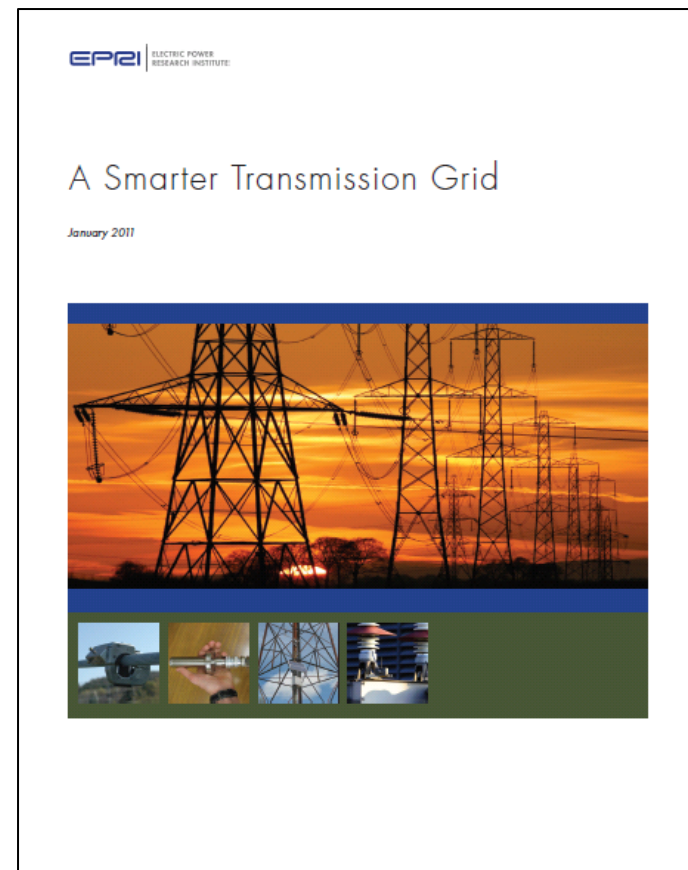

Report is publically available – Product ID: 1022305

Smarter Transmission System

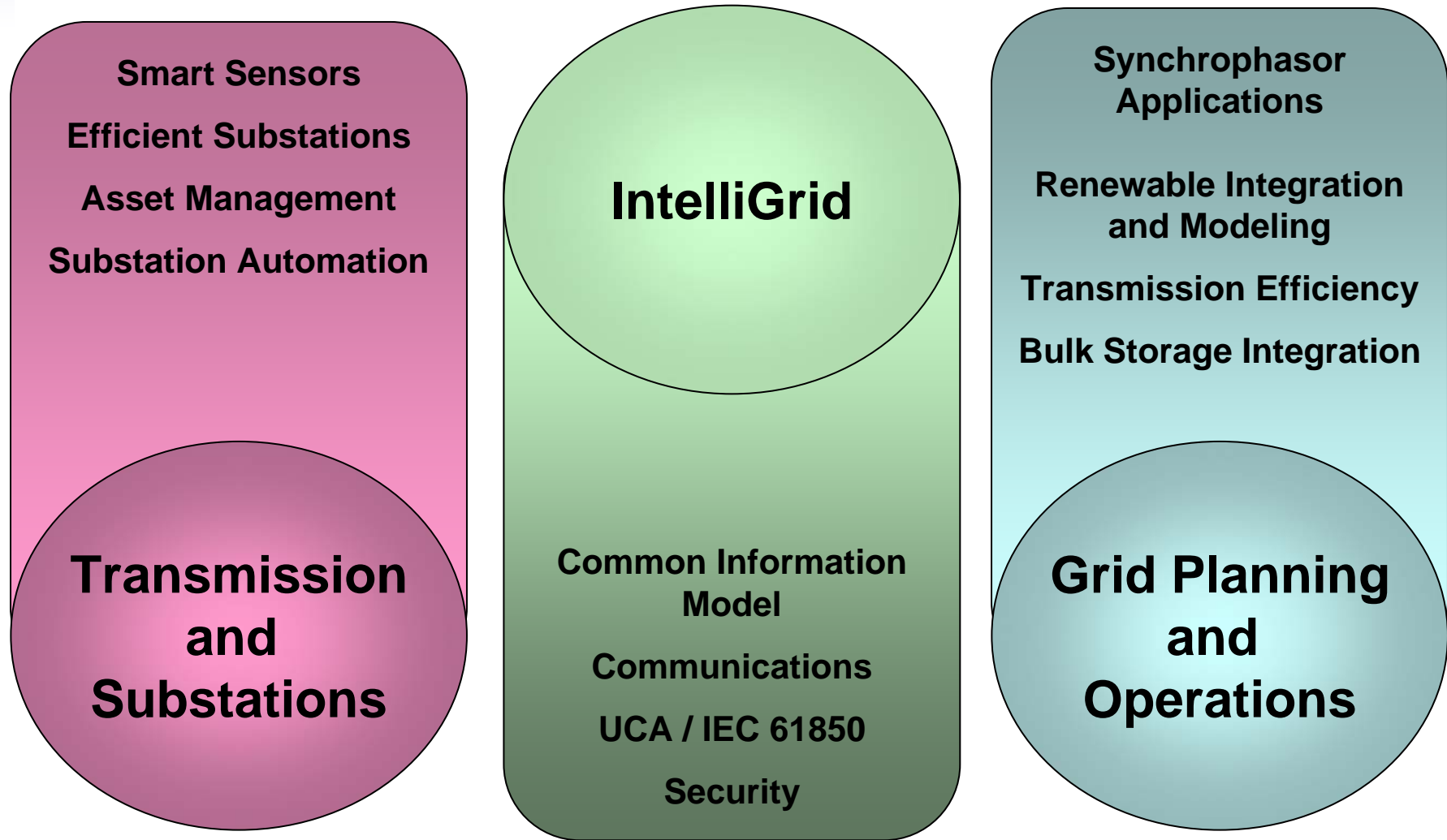

Smarter Transmission System

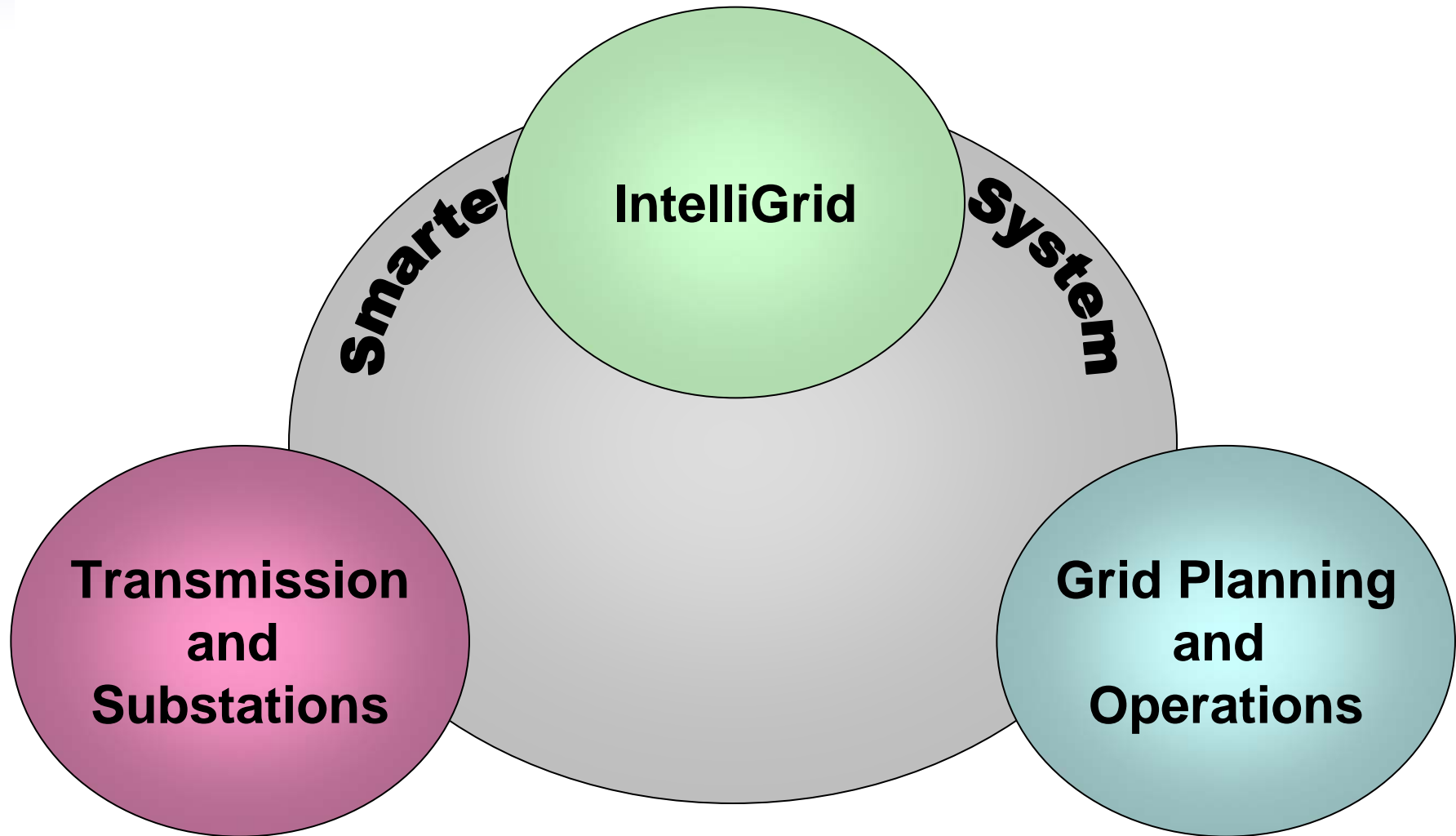

Smarter Transmission Newsletter

First Edition of the “Smarter Transmission” newsletter in final publication stages

Highlights

- **WHAT IS SMARTER TRANSMISSION?**
- **USEFUL INFORMATION**
 - Recent Publications
 - Technology Innovation
 - Upcoming Events
- **FEATURE ARTICLE**
 - NASPInet Demo at North American SynchroPhasor Initiative





NASPInet Demo

Agenda

- Introductions
- Legal Notice
- Smarter Transmission Update
-  NASPInet Demo featuring the Smart Grid Substations Lab
- Grid Transformation
- Upcoming Meetings of Interest

NASPInet Demo Participants



Smart Grid Substation Lab – Featured Project

- NASPInet demonstration
 - Full scale testing of proposed standards
 - Testing of new IEC61850-90-5
 - Hardware
 - Software
 - Wide area communications
 - New “NOOSE” testing

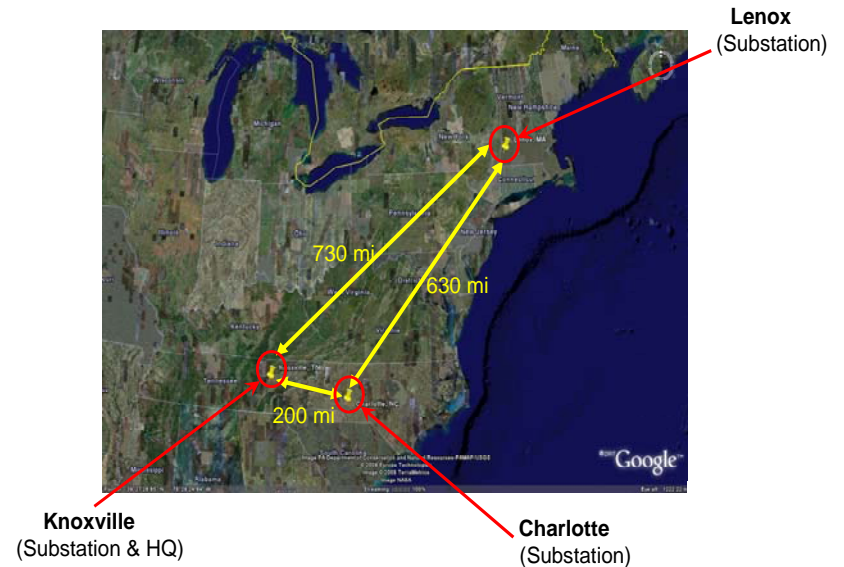

Multi-Vendor collaboration

Supports NIST PAP-13

& IEC 61850 TC57

Demo Goals

- Demonstrate interoperable IEC 61850 90-5 based phasor data exchange over a Wide Area Network (WAN).
- Demonstrate IP Multicast routing of phasor data across the WAN
- Demonstrate common API support for C37.118 & IEC 61850-90-5
- Demonstrate CIM-based PMU Registry data exchange using secure web services over a wide area.

Actual Geography Involved

Verizon provided the communications links between the sites.

Lenox & Charlotte PMUs signals sent to Knoxville.

Knoxville simulating corporate center and sending data to Fort Worth.

Local PMU at Fort Worth also integrated into demo.



Approach - IEC 61850-90-5

Demonstrate interoperable phasor data exchange over a WAN

- Integration of PMU data with protection and control systems
- Facilitate GOOSE packets over WAN
- Integration of PMUs into Substation engineering environments (PMU logical node)
- Enables Subscription to specific PMU data streams
- 90-5 standard version 2 stable

Benefits - IEC 61850-90-5

Demonstrate interoperable phasor data exchange over WAN

- Increase visibility and reliability of the Power System
- Enable wide area protection and control
- Simplifies substation design engineering
- Reduced telecommunication cost
- Supports secure protocol for Phasor data
 - 90-5 key exchange protocol under review in IEC

Network based Publish/Subscribe

No network flooding, simple configuration

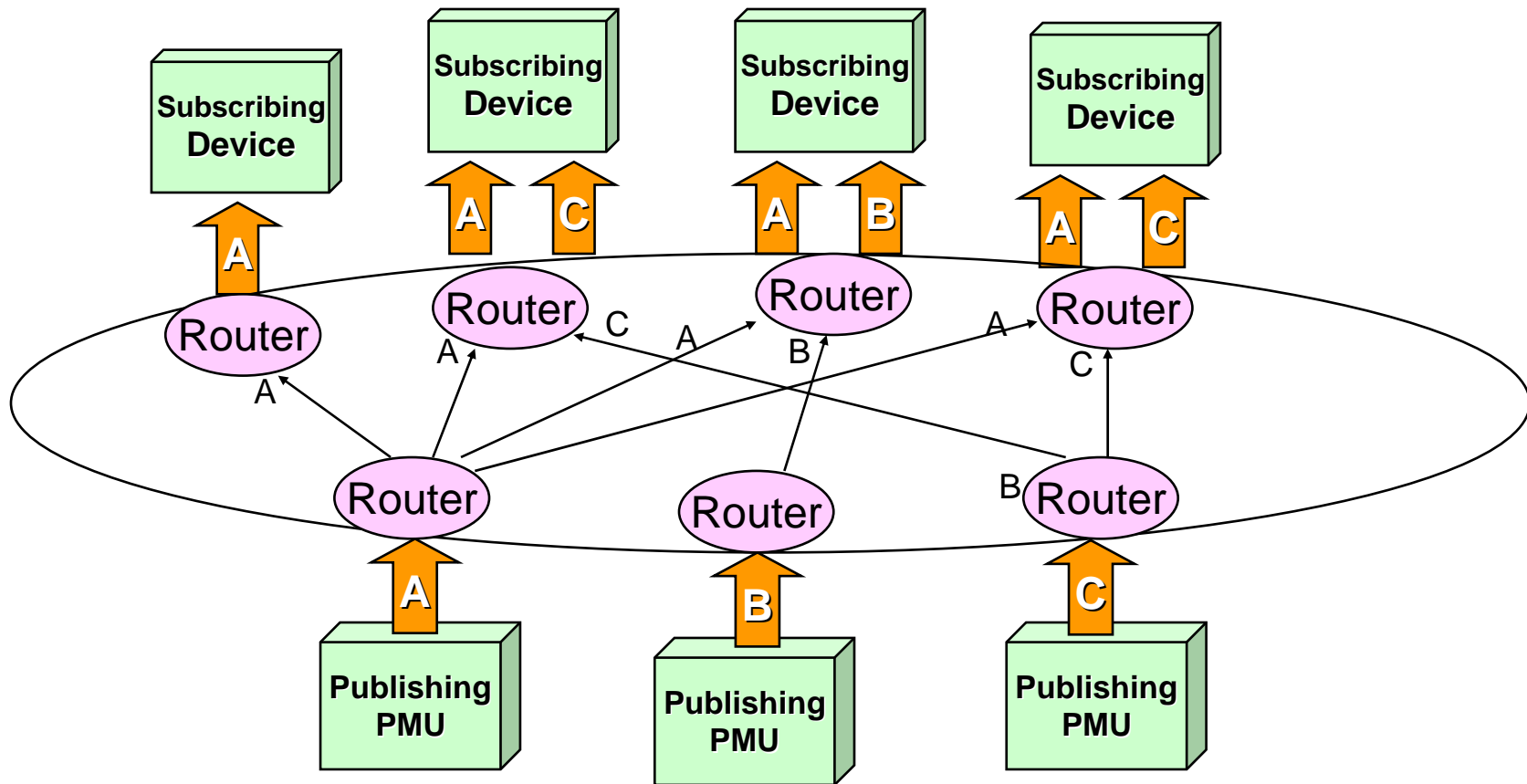

A, B, and C are PMU streams

Approach - IP Multicast

Routing of phasor data across the Wide Area Network as opposed to Unicast

- Network based publish and subscribe paradigm for distributing PMU data
- Source subscription PMU Data via Multicast
- Network Centric approach for PMU data distribution
- Utilizes network protocols for data distribution
- One packet traverses the network (picture)

Benefits - IP Multicast

Demonstrate routing of Phasor data across the WAN

- Reduces PMU network complexity
- Can avoid PDC stacking – Enable low latency
- Reduce PMU processing – single source stream
- Unlimited number of receivers for one PMU source
- Reliable data receipt modes available
- Support C37.118 and 61850-90-5 traffic
- Extensive security measures available

PMU 61850-90-5 over WAN-based IP Multicast

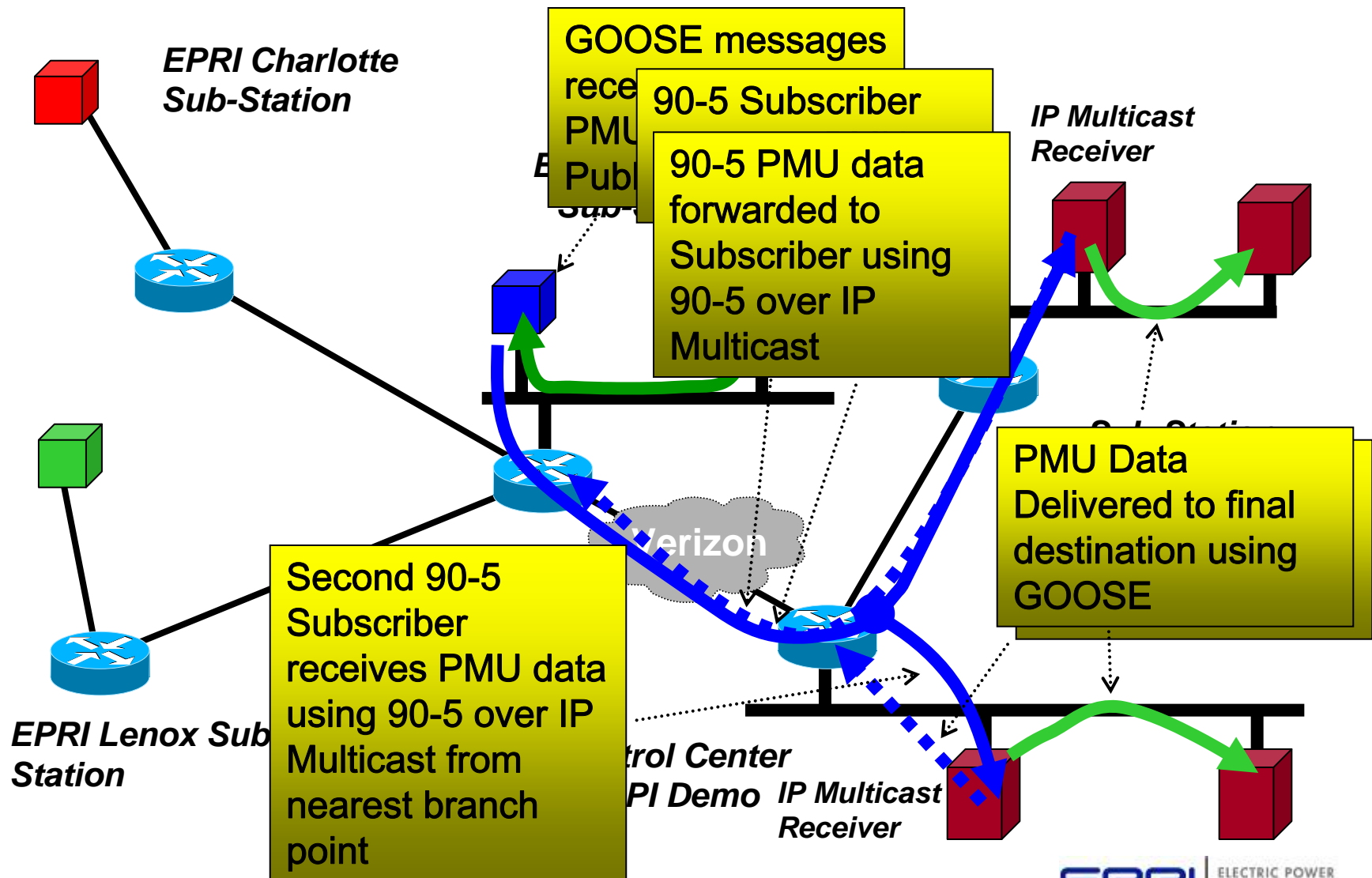

PMU C37.118 over WAN-based IP Multicast

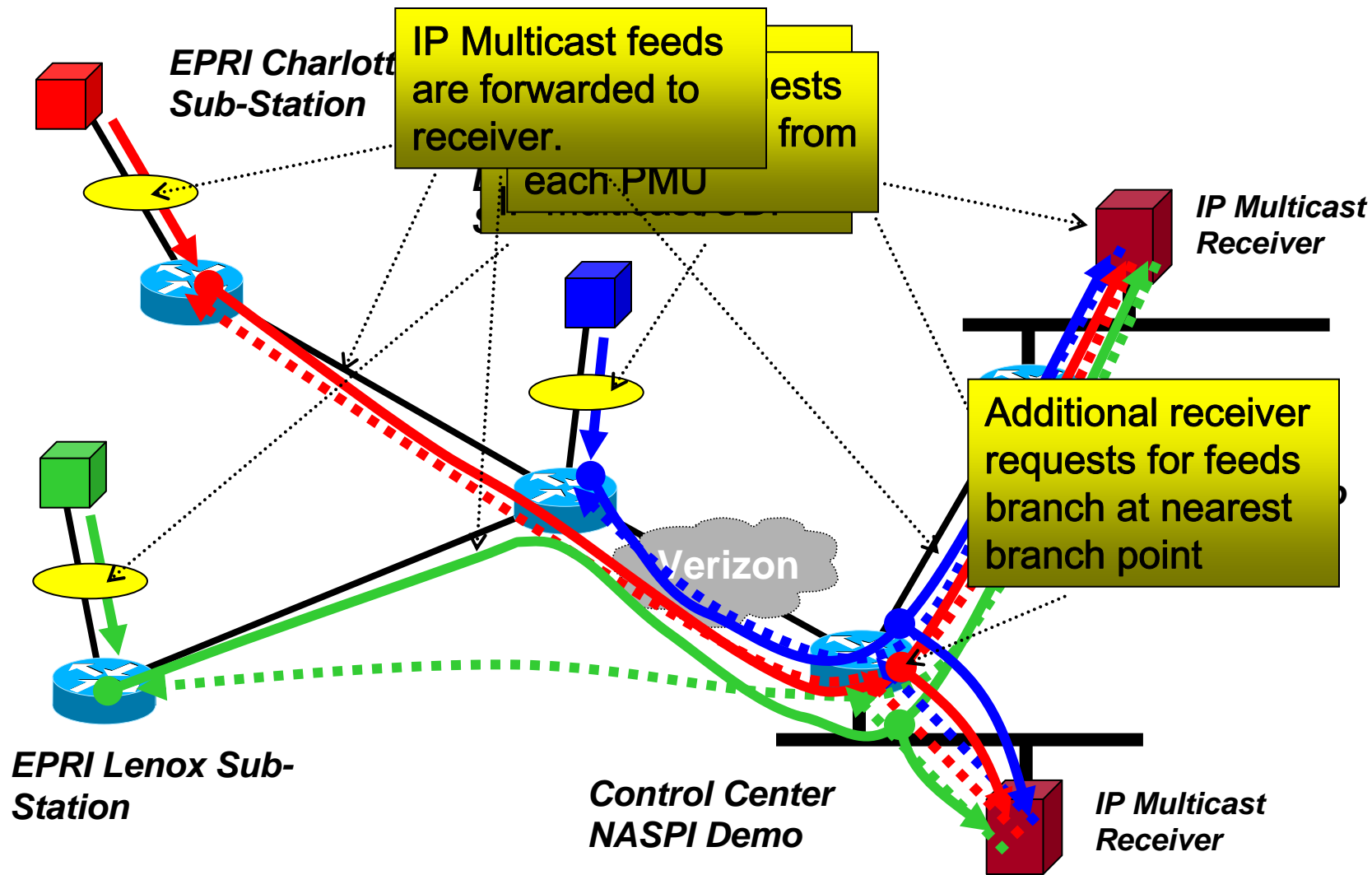

NASPInet with PDC Stacking

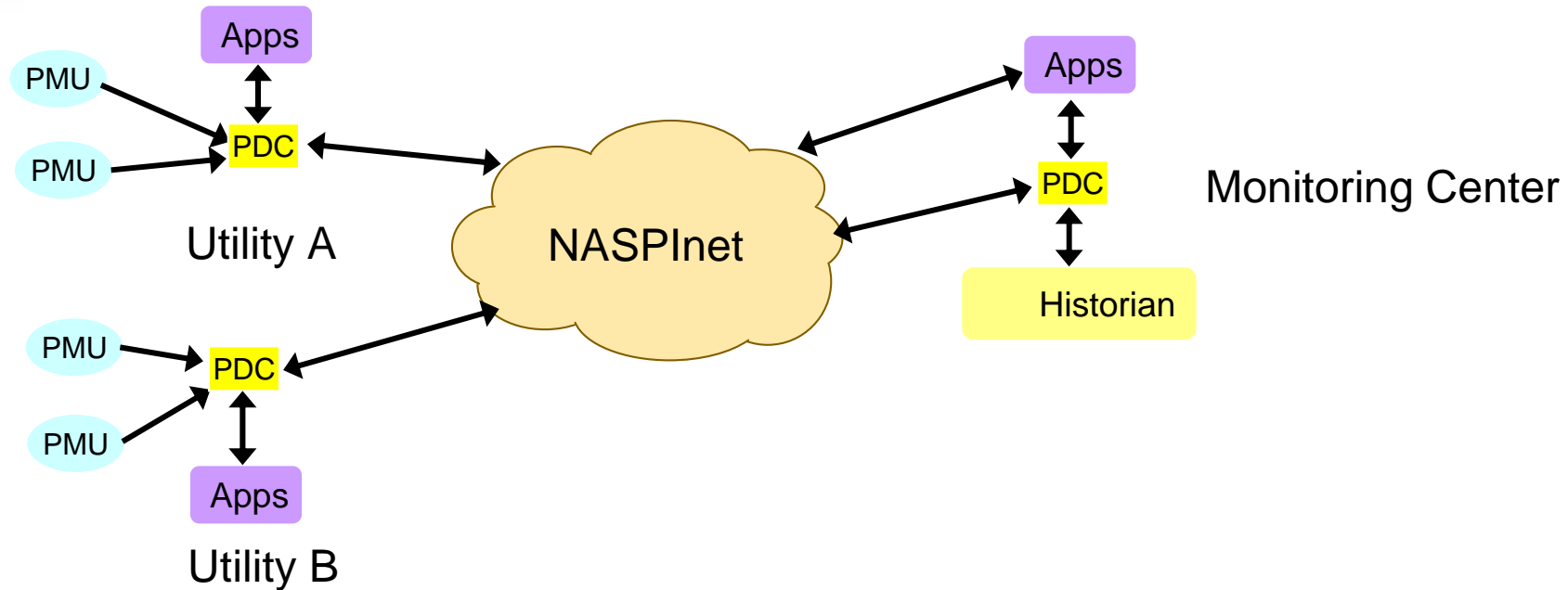

- Conventional architecture utilizes PDC stacking
- Some architectures may have 2 to 6 PDC's in series
- PDC stacking causes application latency and limits throughput

NASPInet w/o PDC Stacking

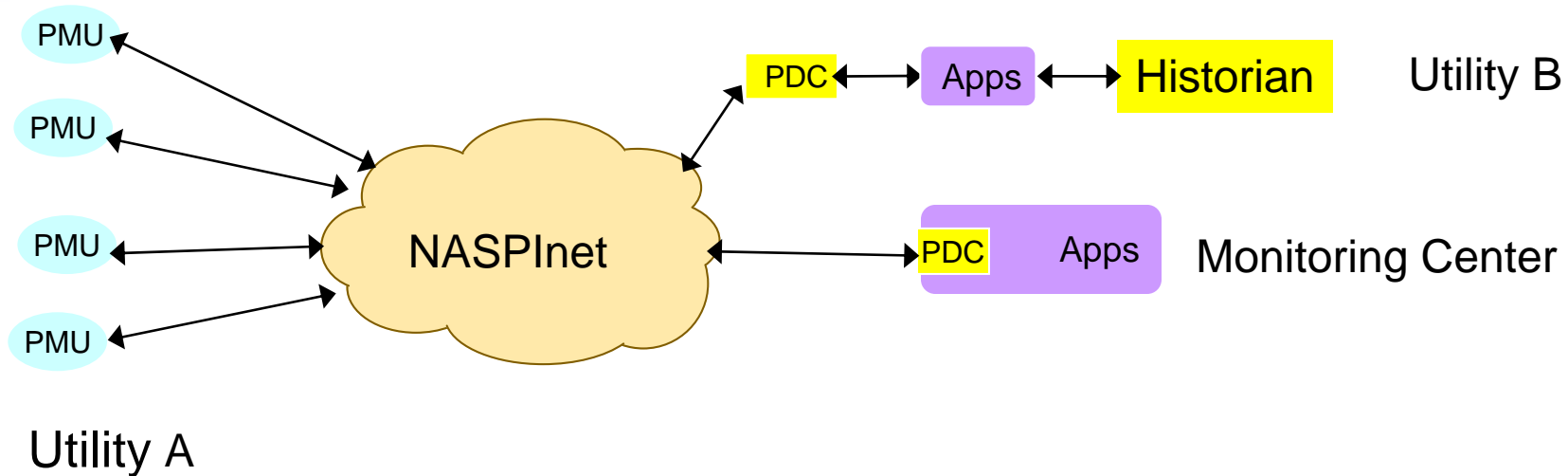

- Multicast can eliminate PDC Stacking
- PDC Function can be located close to application
- PDC functions can reside in:
 - dedicated Servers
 - Applications
 - Historians
 - Routers

Approach - common API

Support for C37.118 & IEC 61850-90-5

- Simplifies migration of legacy protocols & devices
- Enables integration of Phasor measurement data with CIM & PMU registry

Benefits - common API

Support for C37.118 & IEC 61850-90-5

- Reduced migration cost
- Simultaneous support of both protocols
- Eliminates forklift upgrade
- One environment for model driven application development

Approach - CIM-based PMU Registry

Data exchange using secure web services over a Wide Area Network

- CIM - Common Information Model
- Secure exchange of connected power system models with Phasor data
- Support available for historical data, alarms and events

Benefits - CIM-based PMU Registry

Data exchange using secure web services over a Wide Area

- Simplifies registration and subscription of outside Utilities data
- Enables secure power system model synchronization between utilities
- Enables coordinated alarm handling across a wide area
- Support for wide area system analysis for event response

Vendor Applications

Ready to go today!!!

Synchrophasor Data Management

Utility A PDC Utility B PDC ISO PDC

Internet/VPN

PMU(s) A, B, C

CSZ, 19B TCP/UDP Multicast

1 Second Permanent High Resolution Sub-Second

EMS State Estimator Visualization

Substation detail

Primary Regional Host HA Server Secondary Regional Host HA Server

Regional/National Internet

Other Substation Devices (SMF, Meters, OPG)

Expands to total 10 PMUs

OSIsoft

SPACE-TIME-INSIGHT

Phase Lock

- PMU 3 Phase Angle difference (101.88)
- PMU 1 Phase Angle difference (54.55)
- PMU 5 Phase Angle difference (56.48)
- PMU 4 Phase Angle difference (27.01)
- PMU 2 Phase Angle difference (20.88)

Substation	Phase	Frequency	Angle	Amplitude
Substation_1	Phase 1	59.95	101.88	1.0
Substation_1	Phase 2	59.95	54.55	1.0
Substation_1	Phase 3	59.95	56.48	1.0
Substation_1	Phase 4	59.95	27.01	1.0
Substation_1	Phase 5	59.95	20.88	1.0

Demo Network

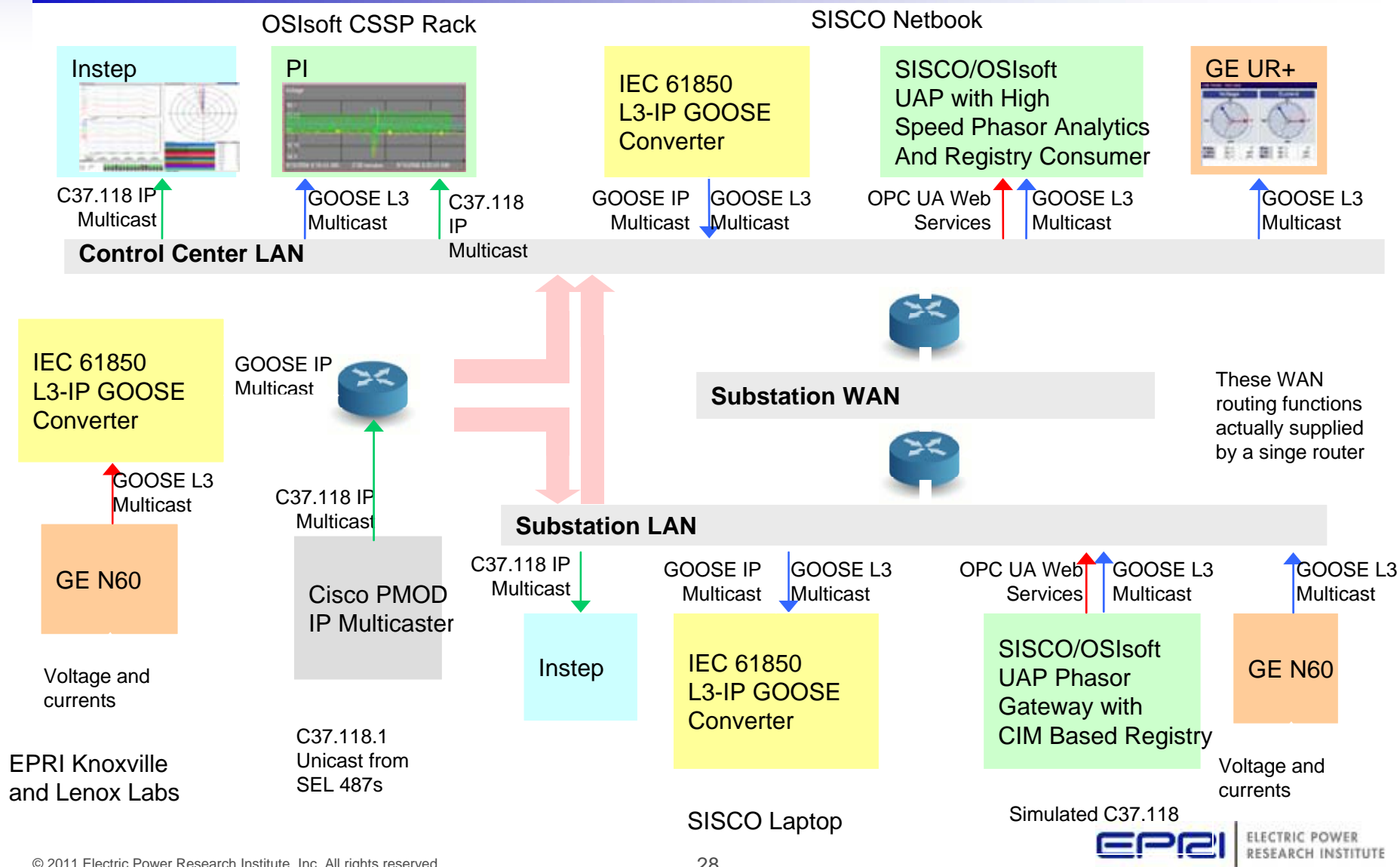

Demo included

- Interoperable IEC 61850 90-5 based phasor data exchange over a wide area.
- IP Multicast routing of phasor data across the WAN
- Common API support for C37.118 & IEC 61850-90-5
- CIM-based PMU Registry data exchange using secure web services over a wide area.

Contact Info

- **CISCO**

Jeffrey Taft
jetaft@cisco.com
724 272-1436

- **GE Digital Energy**

Craig Wester
craig.wester@ge.com
770 729 6368

- **OSisoft**

Chuck Wells
cwells@osisoft.com
(510) 297-5802

- **EPRI**

Paul Myrda
pmyrda@epri.com
708-479-5543

- **InStep**

Anthony Maurer
amaurer@instepsoftware.com
312 894-7851

- **SISCO**

John Gillerman
Johng@siskonet.com
7329379745

- **Space Time Insight**

Chinni Ranganath
chinni.ranganath@spacetimeinsight.com
732.325.5155

- **Verizon**

Alex Meynardi
alessandro.m.meynardi@verizonbusiness.com
610.257.3170



Grid Transformation

Approved Strategic TI project

Agenda

- Introductions
- Legal Notice
- Smarter Transmission Update
- NASPInet Demo featuring the Smart Grid Substations Lab
- Grid Transformation
- Upcoming Meetings of Interest



Tomorrow's Power System

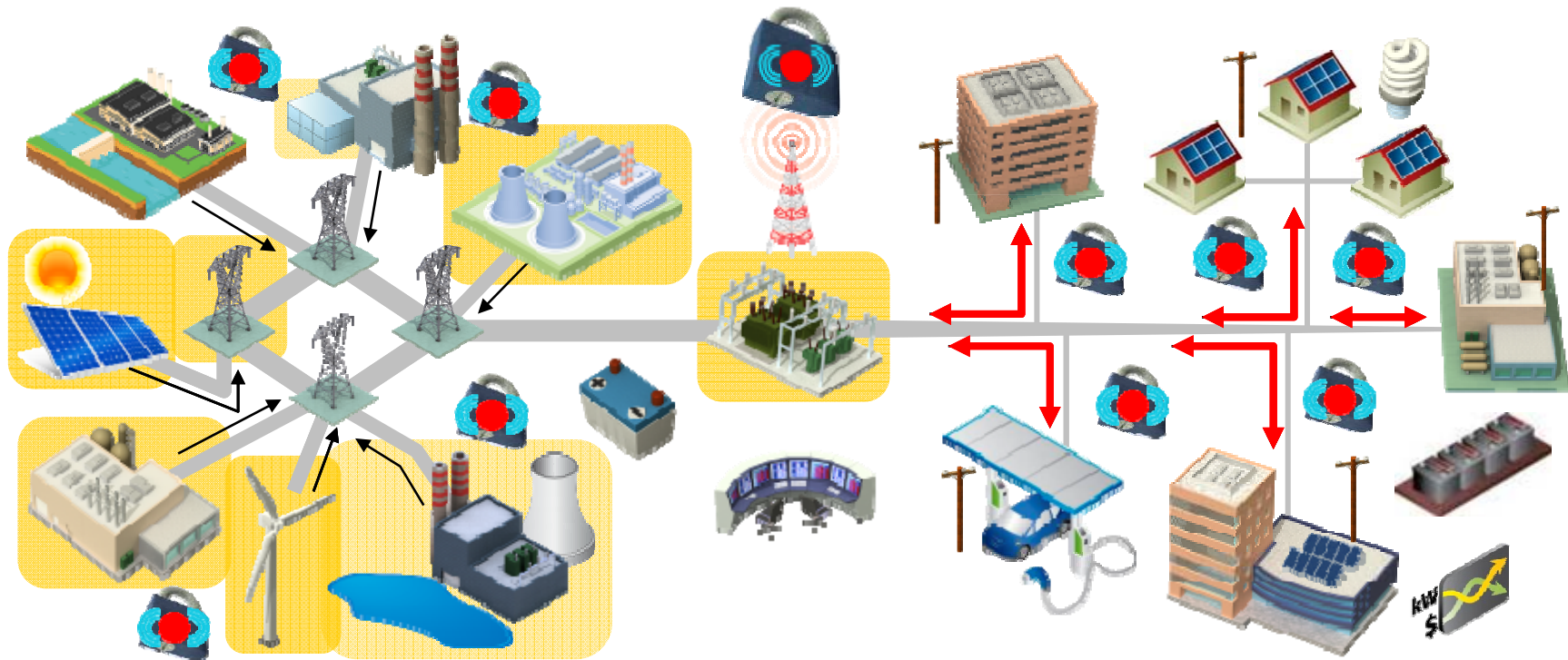

**Managing Future Power System Complexity will
Require a New Grid Operating System**

Example Grid 3.0 Architecture

- What information is needed from each node?
- What data is needed?
- What sensors are needed?
- How is data collected and managed?
- Where does computation occur?
- What controls are needed?

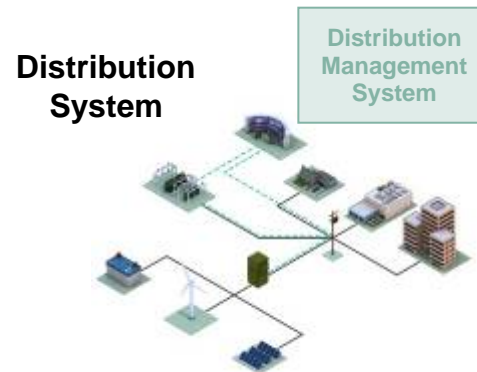
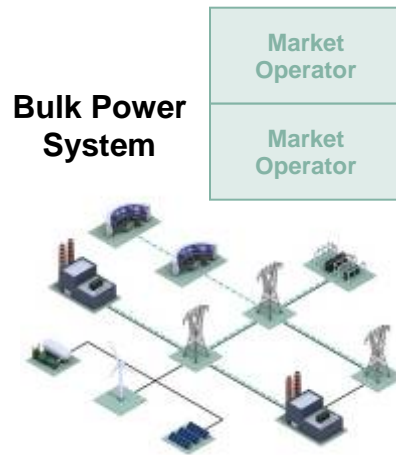

What is the decision hierarchy?

- Optimization algorithms for reliability, security, stability, economics, environment, etc.
- Where will forecasting of resource availability, renewable production and demand occur?

Community LEN



Campus LEN



Building LEN



Grid Transformation and Possible EPRI Activities

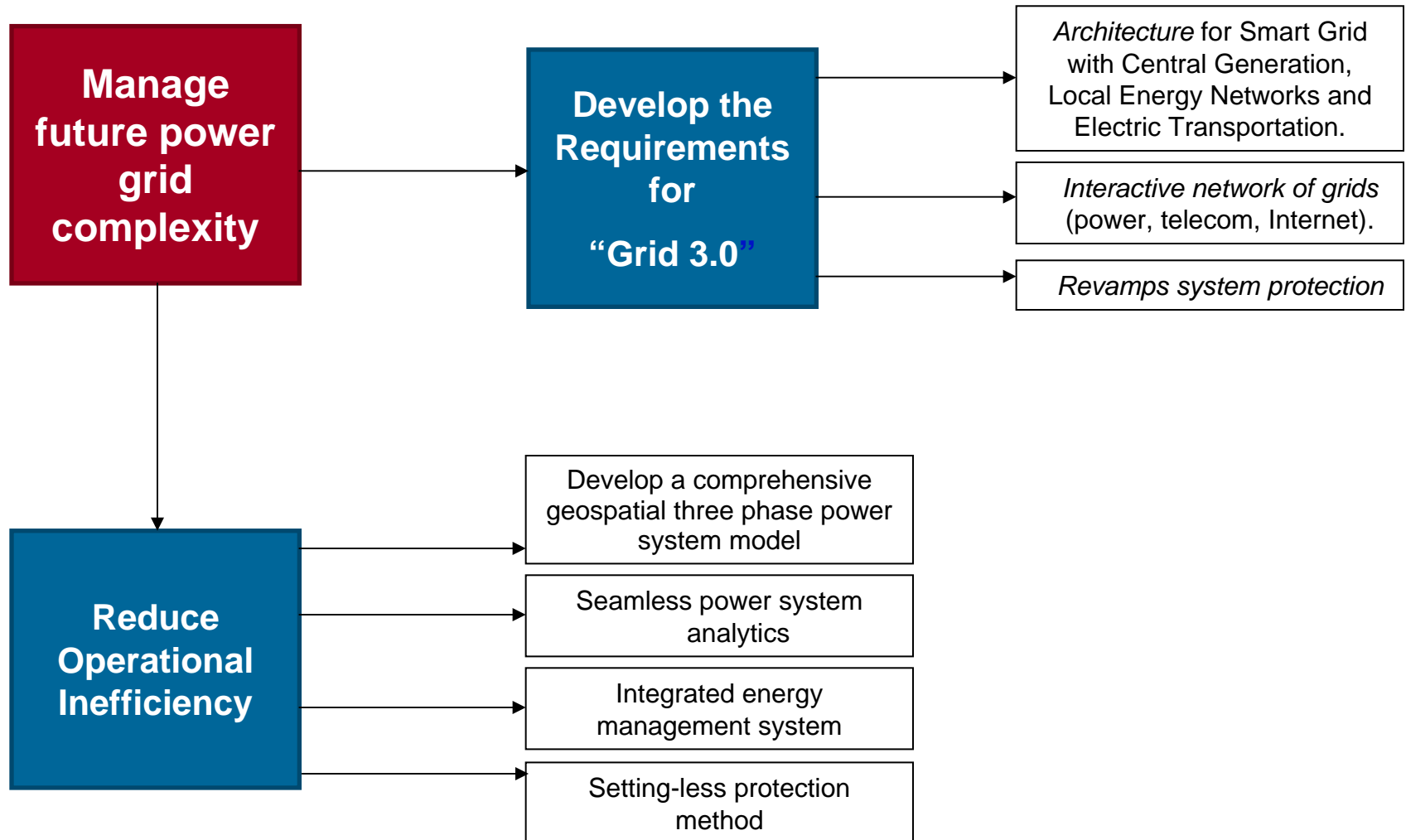

New TI Program Strategy and Scope

- 3-4 focused workshops to define and explore technology concepts suitable to address the Grid Transformation challenges
- Promising solutions will be further refined and functional requirements specified and evaluated against Technology Readiness Level
 - Validation of concepts and prototypes suitable for TI funding
 - Technologies closer to commercial deployment submitted to base and supplemental programs for funding consideration

TRL 1	TRL 2	TRL 3	TRL 4	TRL 5	TRL 6	TRL 7	TRL 8	TRL 9
Exploratory Research	Concepts Formulated	Proof of Concept Validated	Subsystem Validation	System Validated	Early Demonstration	Demonstration	Early Commercial Deployment	Commercialization

TI

Base and Supplemental

Grid Transformation – PDU: TRL Status at Startup, End-of-Year 2011 & Sector Transition

Project	TRL1	TRL2	TRL3	TRL4	TRL5	TRL6	TRL7	TRL8	TRL9
Seamless geospatial three phase power system model requirements concept	2011					2014	PDU (P161)		
Seamless power system analytics requirements development	2011					2014	PDU (P40)		
Integrated energy management system coupled with the above analytics and grid measurements		2011				2014	PDU (P39)		
Setting-less protection method	2011						2015	PDU (P37H)	

 = Anticipated Progress Through EOY11

 = Anticipated Progress at Transition Point

Near Term Grid Transformation Action Items

- Grid Transformation – White Paper in final stages of development
- Planning in progress for 3 or 4 Workshops in Fall 2011
 - Seamless geospatial three phase power system model requirements concept
 - Seamless power system analytics requirements development
 - Integrated energy management system coupled with the above analytics and grid measurements
 - Setting-less protection method

One of the Key Issues

- As a Director, Transmission Planning and Protection at recently said
 - “Today my staff spends 80% of their time building the models and 20% analyzing the results. I would prefer that this be the other way around.”
- Overall issue being addressed
 - Operational inefficiency resulting from the fragmented set of tools and data sources used by planners, operators and protection engineers in managing their portion of grid.

2011 Scope

1. **Identify** utility industry leaders to form an **executive advisory panel – in progress**
2. **Identify** a robust set of industry, national lab and academia **partners** who will **pitch in** with this development – **in progress**
3. **Raise industry awareness** that we have undertaken this effort working with industry & academia experts – **White paper in progress and should be release by end of May**
4. **Industry workshops to gether industry input in the definition and development process – in planning stages, workshops to be held in the fall of 2011**



2011 Meetings Of Interest

Agenda

- Introductions
- Legal Notice
- Smarter Transmission Update
- NASPInet Demo featuring the Smart Grid Substations Lab
- Grid Transformation
- Upcoming Meetings of Interest



Mark Your Calendar

Upcoming EPRI IntelliGrid Advisory Meeting



EPRI IntelliGrid Advisory Meeting

Meetings Dates: June 1-3, 2011

Electric Power Research Institute

3420 Hillview Ave.

Palo Alto, CA 94304

*If you are interested in attending please contact Ashley Eldredge,
aeldredge@epri.com.*

Mark Your Calendar

Upcoming EPRI PDU Advisory Meetings in 2011



Program Meetings: September 12-14, 2011

Council Meetings: September 14-15, 2011

*Westin – Boston Waterfront
425 Summer Street
Boston, MA 02210*

<http://www.westinbostonwaterfront.com/>

EPRI Group Rate: \$199

IEC 61850 Workshop

The two and half day training and workshop will focus on the following topics:

- IEC 61850 overview
- Details of the modeling for substation automation, control and protection
- Substation communication architectures
- Process bus and merging unit
- Engineering process
- Testing and maintenance
- New features and enhancements in IEC 61850 Edition 2
- Use of IEC 61850 outside the substation
- IEC 61850 for a Smarter Grid

Consolidated Edison
Edison Room 19th Floor
4 Irving Place
New York, New York 10003

Wednesday, August 3, 2011 8:00 AM
Friday, August 5, 2011 12:00 PM

The workshop will cover the following special topics of interest:

- Utility presentations addressing challenges, issues, lessons-learned and best practices
- EPRI project briefing: "IEC 61850 Testing Guidelines and Utilities Practices"
- Equipment demonstration
- Demonstration of system integration and testing tools

EPRI Transmission Operations Workshop II

July 19-20, 2011 – Houston, TX

The Workshop will include utility speakers who will present on the key topics listed below:

- Equipment Health Information in Operations
- Power System Data & Model Management
- Synchrophasors and Transmission Sensor Applications
- Compliance Coordination
- Lessons Learned from Recent Extreme Events

Save the Date - July 19-20, 2011 – Houston, TX

North American SynchroPhasor Initiative

- North American SynchroPhasor Initiative - Working Group Meeting is scheduled for **June 8-9, 2011** - Toronto Airport Marriott, Toronto (Mississauga), Ontario, Canada
 - This NASPI work group meeting will feature success stories of synchrophasor technology use by system owners and operators.
 - co-located with the NERCs Operations Committee and Planning Committee meetings (scheduled for June 7-8)
 - Planned topics include: End-to-end Testing Your Synchrophasor System, Oscillation Detection and Mode Meter Tools, PMU Models and Testing, Operator training panel, Owner-Operator Synchrophasor Success Stories, PDCs, Data Archiving and Retrieval.

<http://www.naspi.org/meetings/workgroup/workgroup.stm>

IEEE Power System Relaying Committee

The IEEE Power System Relaying Committee (PSRC) will meet in Asheville, NC on **May 16-19, 2011**.

- The Role of Protective Relaying in the Smart Grid,
- IEEE 1588 Profile for Power System Applications (PC37.238)
- Synchrophasor Data Transfer for Power Systems
- Considerations for “Aurora” Protection
- Cyber Security for Protection Related Data Files
- C37.118 Power Systems Synchrophasors Standard Harmonization with IEC 61850
- Guide for Synchronization, Calibration, Testing, and Installation of Phasor Measurement Units

Many of these activities are driven by the NIST Priority Action Plans activity. <http://pes-psrc.org/>

Together...Shaping the Future of Electricity



EPRI | ELECTRIC POWER
RESEARCH INSTITUTE